

H G F E D C B A

4

3

2

1

4

3

2

1

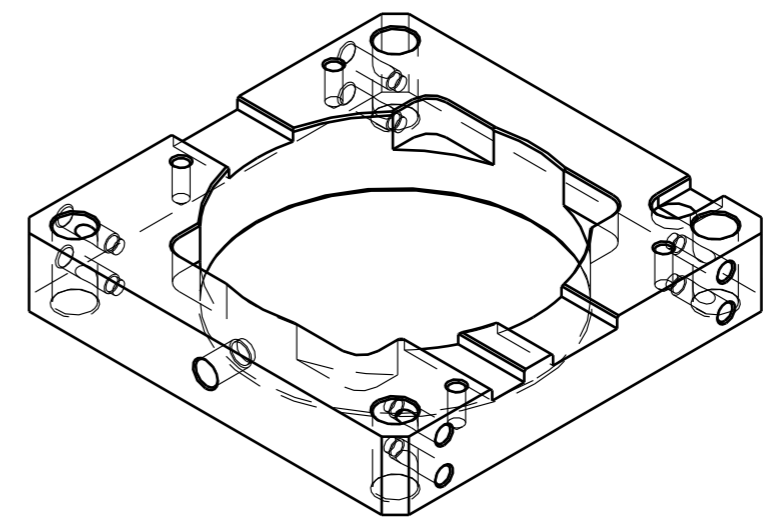
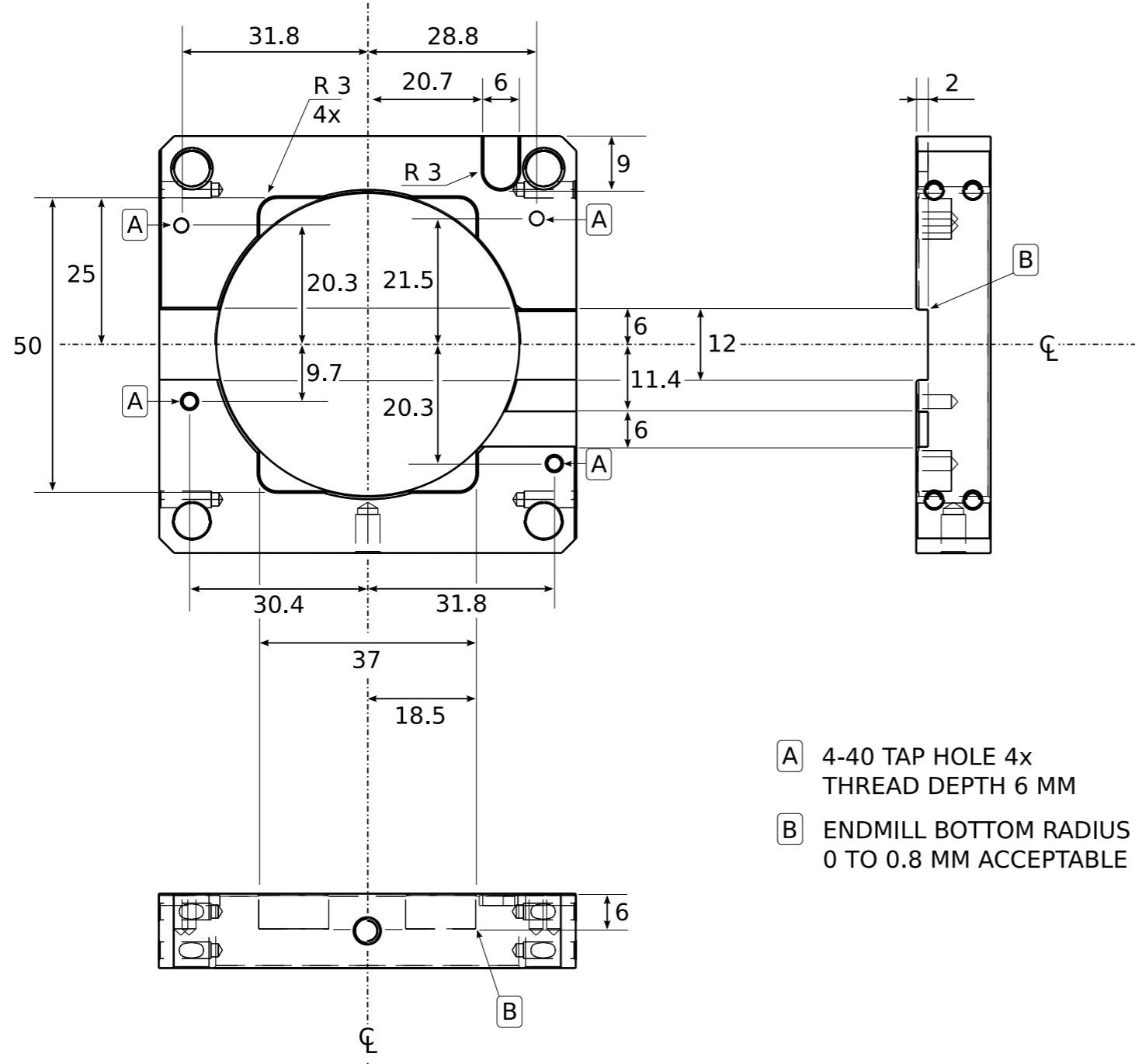

- A 4-40 TAP HOLE 4x
THREAD DEPTH 6 MM
- B ENDMILL BOTTOM RADIUS
0 TO 0.8 MM ACCEPTABLE

ORIGINAL PART: THORLABS LCP01
 ALL MILLING: 6 MM DIA ENDMILL FROM TOP SIDE
 TOLERANCE: 0.2MM UNLESS NOTED
 OPTIONAL 0.3MM CHAMFER ON ALL OUTER EDGES
 FINISH: BLACK MATTE ANODIZED ON ALL SURFACES

DESIGNED BY: Stan Skowronek		<h1>LCP01-BigCam</h1>		I	-
DATE: 07/23/2011				H	-
CHECKED BY:				G	-
DATE:		F	-	E	-
SIZE: A3		ALL DIMENSIONS IN MM		D	-
SCALE: 1:1		WEIGHT (kg):	DRAWING NUMBER: Rev A3	SHEET: 1	C
				B	-
				A	-

H G B A